

**NEW**

- 500 KG capacity
- 19 mt working height
- 14 mt max outreach
- 3 operators in the basket
- auto balance connection
- 4WD+4WS
- engine 55kW TIER V READY

**Provisional**



PLATFORM BASKET

**RR19-DD**

**RAIL ROAD ACCESS PLATFORM**



# RR19-DD

## Main features

The new Rail Road RR19-DD is the new development of Platform Basket for the Railway Market.

The Project starts from the experience of Platform Basket both on MEWP (Mobile Elevating Working Platform) and Rail Road working Platform (the well-known RR14-EVO2-400 & RR14-EVO3-400).

The Purpose with this new machine is to give a high height working platform (approx 19m) with a big capacity in the basket (500kg) along with 3 operators allowed in the cage.

With these features, the new RR19-DD500 wants to cover the construction issues for aerial work on rail, that now are not possible due to the height limit of the actual machine.

Also, in order to give more versatile to the system, in the next future it will be possible to feat the RR19-DD with some tools along with the platform as RR14-EVO3-400

The platform will be equipped with a control panel on ground and a control panel in the basket  
The machine is so equipped with a fast connection system of the Basket/tool and an electric 7kW generator

# TECHNICAL DATA ON THE RAILWAY (1435mm gauge)

max working height (static)	19,00 m
while driving (dynamic)	
max. lateral outreach (static)	14,00 m
while driving (dynamic)	
max. lateral outreach (static)	9,30 m

rotation angle (mech. Set up)	% deg 180 + 180
basket rotation	% deg 90 + 90
length in stowed position	9,50 m
min. stowed width	2,40 m
min. stowed height	3,00 m
Max driving speed in travelling mode	14 km/h
Max travelling speed in working mode	5 km/h
minimum turning radius	40 m
max turning slope (CANT)	200 mm
main engine power	55 kW (75 Hp)
auxiliary engine power (Optional)	7 kW (9,5 Hp)
basket swl	500 kg
active oscillating axle	yes (double)
max allowed wind speed	45 km /h
active oscillating axle	yes
max allowed wind speed	45 km /h

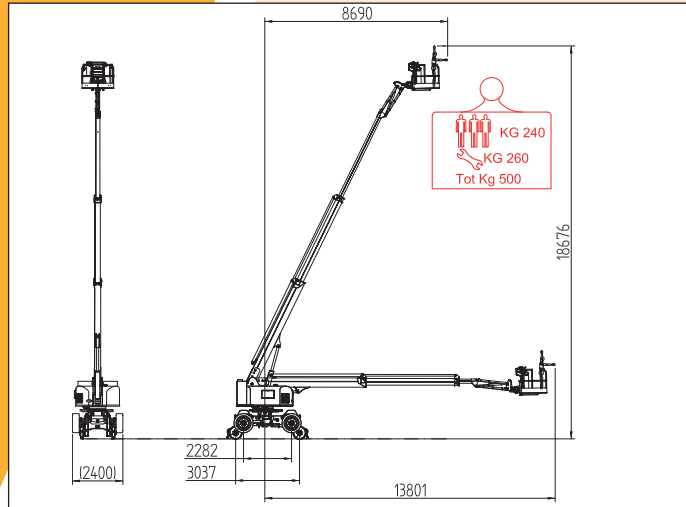

### Main working fields:

- Over-head line installation & maintenance
- Signal maintenance, station maintenance
- Bridge and tunnel maintenance
- Building construction works, trackside arboriculture.

## GENERAL FEATURES

# RR19-DD

basket dimensions	1,2x1,5 m
driving speed	4,0 km/h
steering outer radius 4ws	4,20 m
steering inner radius 4ws	1,80 m
tyre size (foam filled)	12.5 x 18"
oil reservoir	70 L
fuel reservoir	100 L
weight	19500 kg
steering inner radius 4ws	1,80 m
tyre size (foam filled)	12.5 x 18"

max operating slope on tyres	% deg 3
max gradient	29%
electric circuit	24 Vdc
battery power	50 A/h (815 cranking)
complete diagnostic display	yes
Keyboard & data logger	yes
4 wheels drive	yes
4 wheels steering	yes

